

INSTALLATION INSTRUCTIONS FOR GM Upper Control Arm Bracket Punch Tool Instructions

1. Locate jack under the lower control arm as near ball joint as possible. Raise vehicle and remove wheel.
2. Remove the bolts holding the upper control arm to frame and move control arm out of way.
3. Locate OE knockout slug on frame and install punch into OE bolt hole with threaded end facing front of vehicle.
4. Install the channel shaped part of punch with the open end facing toward the rear of vehicle as shown in figure. Install the washers and nut as shown.
5. After insuring that the punch is properly aligned with the slug in the control arm, tighten nut until the tool punches the slug out of bracket.
6. Repeat steps 3 through 5 for other control arm bracket and install control arm using K6302 Cam bolt kit.
7. Repeat entire procedure for other side of vehicle if necessary.

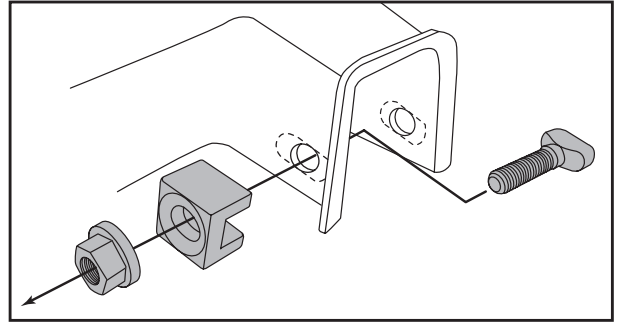

CAUTION: Proper service and repair procedures are essential for safe and reliable installation of chassis parts, and require experience and tools specially designed for the purpose. These parts MUST be installed by a qualified mechanic. otherwise an unsafe vehicle and/or personal injury could result.